

06IP/IM74 OPERATIONS RESEARCH

UNIT - 6: PROJECT MANAGEMENT USING NETWORK ANALYSIS

(By Dr.G.N.MOHAN BABU, Prof & HOD (I&P Engg), MCE, Hassan 573 021)

LEARNING OBJECTIVES OF THE MODULE:

By the end of this module we will learn about:

- Projects, their Management and Terminology used
- Construction of project networks
- Project management techniques: CPM and PERT
- CPM - Determination of minimum project duration
 - Flexibility in executing project activities
 - Shortening (Crashing) the project duration
- PERT- Handling probabilistic activity-time estimates

'Project' is not a new word for any of us. We read about new technology development (3G mobiles, vaccine for H1N1), Implementation of new transport system (Metro, Petronet), Quality improvement program (TEQIP), New civil construction (stadium, factory), etc. The common features among these entitle them to be called as Projects.

Definition of Project: A project is a temporary endeavor with a collection of interrelated activities with each activity consuming time and resources. It is designed to achieve a specific and unique outcome and is subject to time, cost and quality constraints.

Project Management (PM):

Proper planning, scheduling, executing and controlling of project activities is required to ensure that the projects are completed within the stipulated time and budget, complying to all quality and safety requirements. A good PM utilizes the resources most effectively.

Several analytical techniques such as PERT, CPM, PEP, RAMPS have been developed to aid real time project management.

The phases that comprise PM can be identified as (i) Project planning, (ii) Project scheduling and (iii) Project executing and Controlling.

Project Planning phase involves :

- Setting project objectives and scope
- Preparing Work Breakdown Structure (WBS)
- Estimating activity time and resource requirements
- Identifying the interrelationships between activities
- Arranging activities for network analysis

Project Scheduling involves:

- Determining the start and finish times for each activity
- Determining the critical path and flexibility in each activity

- Communicating schedule using visual aids (Gantt chart)

Project Executing and Controlling involves:

- Carry out the project activities as per plan and schedule
- Periodically evaluate and correct the project progress
- Crash project duration if necessary (resource reallocation)

An effective feedback system should be present to take into account the realities on site and incorporate the changes, if any, into the project plan updating it.

Pictorial representation of Phases of Project Planning and Scheduling

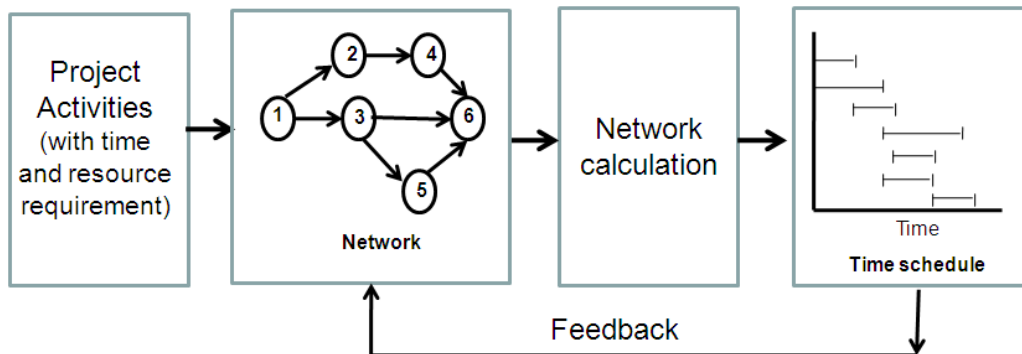

Terms used in network analysis:

WBS: Break down the project into constituent activities such that each activity is clearly identifiable and manageable

Activity: This is a physically identifiable part of the project that consumes time and resources. It is represented by an arrow (in AOA diagrams)

Events (node): These are the beginning or end points of an activity. Event is a point in time and does not consume any time or resource and is represented by a circle.

Path: This is a continuous chain of activities from the beginning to the end of the project

Network: A graphical representation of logically and sequentially arranged arrows and nodes of a project. It indicates the interrelationships between the activities of a project

AOA (Activity-On-Arrow) Diagram: A network with activities represented on arrows and event on nodes. Often dummy arrow is needed to establish precedence relationship which makes the network a little cumbersome and requires greater computation. But it is easily understandable.

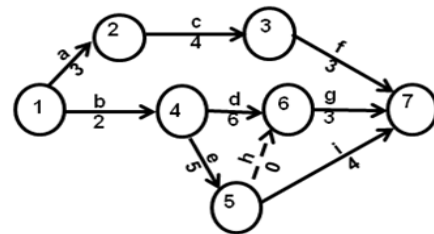

AON (Activity-On-Node) Diagram: A network with activities represented on Nodes. Arrows indicate only the interdependencies between them. The use of dummy activities can be avoided

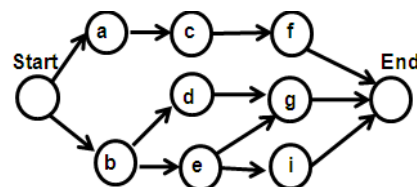

Network Construction:

Know the Interrelationships: For a network representation of a project, first we need to know the interrelationships between activities such as (i) Which activities follow a given activity (successors) ?, (ii) Which activities precede a given activity (predecessors) ? and (iii) Which activities can be executed concurrently with a given activity ?

Know the Guidelines for Construction: Then we need to follow the rules given below. (i) Activities progress from left to right (Time flows rightwards), (ii) Each activity is represented by only one straight and solid arrow, (iii) No two activities can be identified by the same end events, (iv) An activity which shows the logical relationship between its immediate predecessor and successor activities, but does not consume time and resources is represented by a dummy activity (dashed-line arrow), (v) Arrows should not cross each other as far as possible and (vi) Avoid Curved arrows, Dangling arrows, and Looping of network

Know to Number the events: (i) The initial event with only outgoing arrows and no incoming arrows is numbered as 1, (ii) Delete all arrows going out of event 1. This will convert in some more events into initial ones. Number them 2, 3, ..., (iii) Delete all arrows going out of these events too. This will yield some more initial events. Numbering them further as was done previously and (iv) Continue until the final node is reached which has only incoming arrows and no outgoing arrow.

Problem 1. Draw an economical AOA n/w using the following data

Job	Predecessor	Job	Predecessor	Job	Predecessor
A	-	F	A	L	G, H
B	-	G	F	M	J, K, L
C	A	H	D, E	N	J, K, L
D	A	J	G, H	O	K, J
E	B, C	K	G, H		

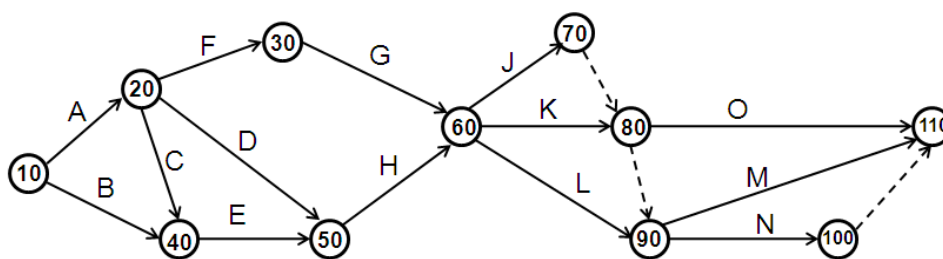

Problem 2. (solved in ppt). Represent the following set of activities on a network:

Activity Task	Symbol	Imm. Predecessor
Open the petrol tank cap	A	-
Add petrol (Paid service)	B	A

Close the petrol tank cap	C	B
Open bonnet	D	-
Check and add engine oil (Paid service)	E	D
Check radiator coolant	F	D
Check battery	G	D
Close bonnet	H	E,F,G
Clean the wind shield	I	-
Check air pressure in tires	J	-
Prepare bill	K	B,E
Collect payment	L	K

Critical Path Method (CPM):

CPM was developed by E I du Pont de Nemours & Co. (1957) for construction of new chemical plant and maintenance shut-down. CPM does not incorporate uncertainties in job-times, thus usable for projects with activities having single time estimates, which can be arrived at with prior experience on similar projects. It assumes activity time is proportional to the resources allocated to it (within a certain limit). CPM is mostly suitable for construction type projects. The objective of using CPM is to determine Critical path, Minimum project duration and Floats available with each activity.

Project Evaluation and Review Technique (PERT):

This technique was developed by the U S Navy (1958) for the POLARIS missile program. The project involved coordination of thousands of contractors and agencies. With the help of PERT, the project got completed 2 years ahead of schedule. PERT is suitable for Non-repetitive projects (ex. R & D work), where job-times are not estimable with certainty *a priori*. PERT uses multiple estimates of activity-time (probabilistic nature). The technique emphasizes on the completion of various stages of a project. Jobs that may cause delays are known in advance in terms of their variability.

Critical Path Analysis:

Problem 3. Suppose a robot building firm plans the following project. Draw the n/w and find the Critical path

Project Activity		Immediate predecessor	Activity duration in days
a	Design a new robot	-	20
b	Build prototype units	a	10
c	Test prototypes	b	8

d	Estimate material costs	a	11
e	Refine Robot design	c, d	7
f	Demonstrate Robot to customer	e	6
g	Estimate labor costs	d	12
h	Prepare technical proposal	e	13
i	Deliver proposal to customer	g, h	5

Project Network:

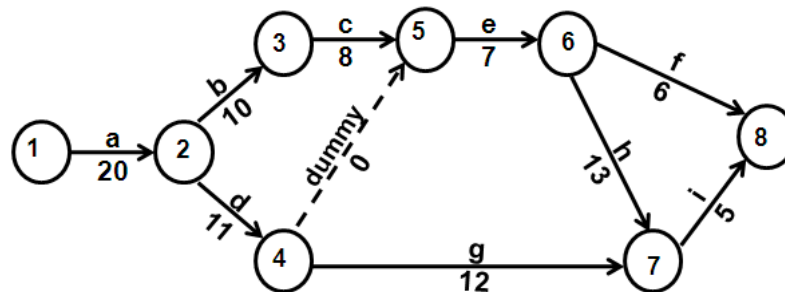

List of all possible sequences (chain/path) of activities (Enumeration method):

Path / Sequence		Total duration
a-b-c-e-f	1-2-3-5-6-8	20+10+8+7+6 = 51 days
a-b-c-e-h-i	1-2-3-5-6-7-8	20+10+8+7+13+5 = 63 days (Critical Path)
a-d-e-f	1-2-4-5-6-8	20+11+0+7+6 = 44 days
a-d-e-h-i	1-2-4-5-6-7-8	20+11+0+7+13+5 = 56 days
a-d-g-i	1-2-4-7-8	20+11+12+5 = 48 days

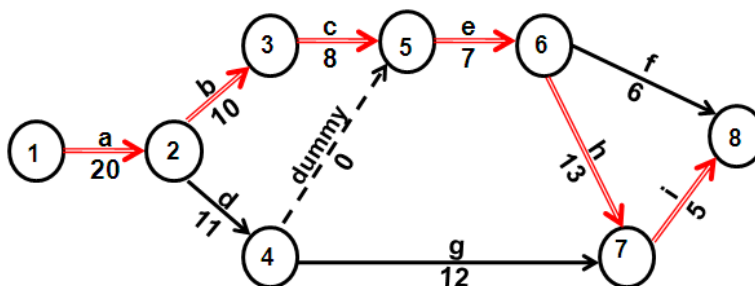

Problem 4. (solved in ppt). A small maintenance project consists of the following 10 jobs whose precedence relationships are identified by their node numbers. Draw an AOA diagram and identify the CP by enumeration method.

Initial Node	Final Node	Duration (days)
1	2	2
2	3	3
2	4	5
3	5	4
3	6	1
4	6	6
4	7	2
5	8	8
6	8	7
7	8	4

Limitations of enumeration method: (i) Very difficult to use when the complexity of network increases, (ii) No information on flexibility available with respect to activities, (iii) Difficult to schedule activities in complex networks

Hence, we use a Structured method for Network analysis

Structured approach:

Here, CP calculations involve TWO passes

Forward pass: To determine the Earliest Occurrence (EO) times of events. The computations start at Node 1 and advance recursively to the last Node n

Initial Step: Set $EO(1) = 0$, as project starts at time 0

General Steps for determine $EO(j)$:

1. Consider separately, each node (say, i) from where an activity is directly converging into node j
2. Add $EO(i)$ and the corresponding activity time t_{ij}
3. Select the maximum of them as $EO(j)$

The forward pass is complete when $EO(n)$ is computed

Backward Pass: To determine the Latest Occurrence (LO) times of events. The computations start at the last Node n and end at Node 1

Backward pass starts after the Forward pass is completed

Initial Step: Set $LO(n) = EO(n)$, as acceptable project delay is 0

General Steps for determine $LO(i)$:

1. Consider separately, each node (say, j) to which an activity is directly reaching from node i
2. Subtract activity time t_{ij} from the corresponding $LO(j)$
3. Select the minimum of them as $LO(i)$

The Backward pass is complete when $LO(I)$ is computed

An event j will be critical, if $EO(j) = LO(j)$

An activity ij will be Critical, if it satisfies the following three conditions:

- 1) $EO(i) = LO(i)$
- 2) $EO(j) = LO(j)$
- 3) $LO(j) - LO(i) = EO(j) - EO(i) = t_{ij}$

Otherwise the activity is Noncritical

For an activity ij , $LO(j) - EO(i)$ gives the maximum span during which the activity may be scheduled

Problem 5. Determine the Critical Path for the activity data given below. All durations are in days.

Initial Node	Final Node	Duration (days)
1	2	5
1	3	6
2	3	3
2	4	8
3	5	2
3	6	11
4	5	0
4	6	1
5	6	12

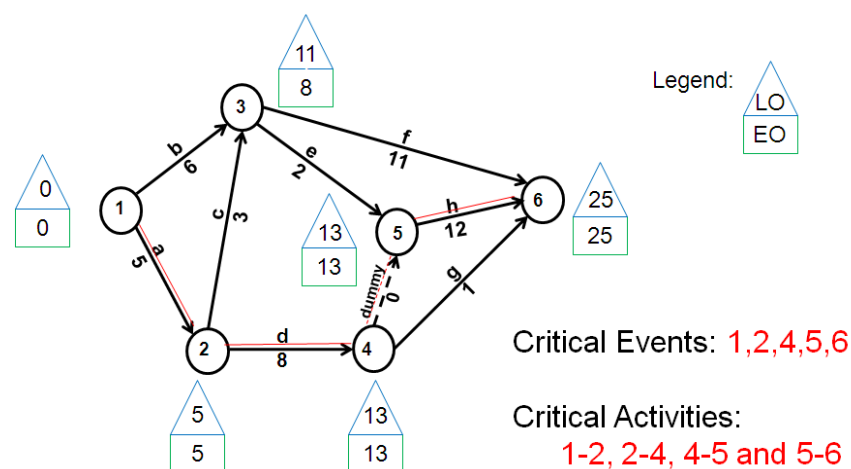

Calculate the floats associated with each activity using the above information

Calculation of floats associated with activities:

Total Float: The time by which an activity ij can be delayed without affecting the project duration

$$TF(ij) = \{ [LO(j) - EO(i)] - t_{ij} \}$$

Free Float: The time by which an activity ij can be delayed without affecting the $EO(j)$

$$FF(ij) = \{ [EO(j) - EO(i)] - t_{ij} \}$$

Independent Float: The time by which an activity ij can be delayed without affecting the floats of any other activity

$$IF(ij) = \{ [EO(j) - LO(i)] - t_{ij} \}$$

All floats are zeros for a Critical activity.

The information about the occurrences of events can be used to develop time schedule and calculate floats for all activities

Activity $i-j$	t_{ij}	ES(ij)	EF(ij)	LS(ij)	LF(ij)	TF(ij)	FF(ij)	IF(ij)
1-2	5	0	5	0	5	0	0	0
1-3	6	0	6	5	11	5	2	2
2-3	3	5	8	8	11	3	0	0
2-4	8	5	13	5	13	0	0	0
3-5	2	8	10	11	13	3	3	0
3-6	11	8	19	14	25	6	6	3
4-5	0	13	13	13	13	0	0	0
4-6	1	13	14	24	25	11	11	11
5-6	12	13	25	13	25	0	0	0

Problem.6. For the given project activity data, compute:

- 1) Critical Path
- 2) Early Start
- 3) Early Finish
- 4) Late Start
- 5) Late Finish
- 6) Total Float
- 7) Free Float and
- 8) Independent Float

Initial node	Final Node	Duration (days)
A	B	9
A	C	3
B	C	2
B	D	14

C	D	8
C	E	2
C	F	7
D	G	5
E	G	6
E	H	4
F	H	4
G	H	6
G	I	2
H	I	6

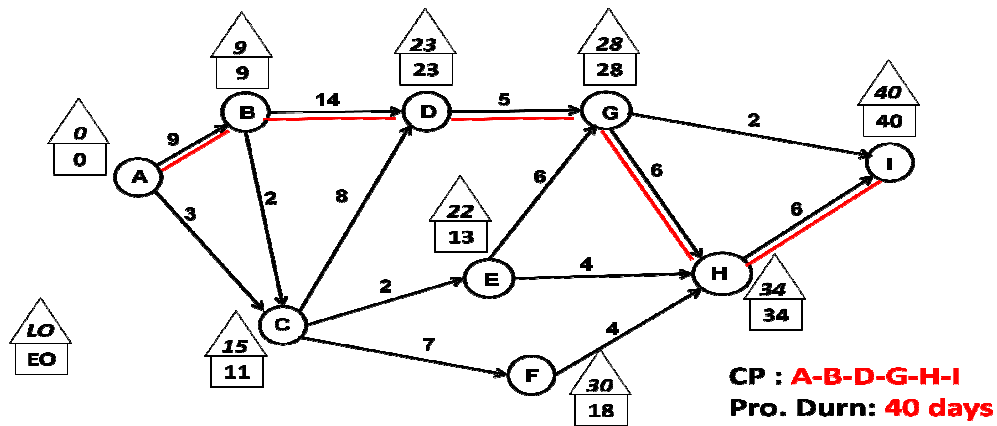

Node i	Node j	Durn.	ES	EF	LS	LF	TF	FF	IF
A	B	9	0	9	0	9	0	0	0
A	C	3	0	3	12	15	12	8	8
B	C	2	9	11	13	15	4	0	0
B	D	14	9	23	9	23	0	0	0
C	D	8	11	19	15	23	4	4	0
C	E	2	11	13	20	22	9	0	-4
C	F	7	11	18	23	30	12	0	-4
D	G	5	23	28	23	28	0	0	0
E	G	6	13	19	22	28	9	9	0
E	H	4	13	17	30	34	17	15	8
F	H	4	18	22	30	34	12	12	0
G	H	6	28	34	28	34	0	0	0
G	I	2	28	30	38	40	10	10	10
H	I	6	34	40	34	40	0	0	0

Crashing Project Duration:

In many situations it becomes necessary to cut down the project duration. How can it be done? Activities that are critical need to be crashed in order to reduce the project duration as it is these activities that determine the project duration. But this has got its own cost implications. Reduction in project duration calls for more resources to be pumped in and hence, the direct costs increase. Whereas indirect costs such as equipment rent, supervision charges, etc. reduce. Thus, it becomes necessary to identify a project duration up to which the project can be crashed so that over all project costs are minimum.

Problem.7. Find the lowest cost schedule of the following project given the overhead expenses as Rs.45,000/- per day.

Activity	Normal duration	Crash duration	Cost of crashing (x1000 Rs/day)
1-2	3	1	40
2-3	4	2	40
2-4	7	3	10
3-4	5	2	20

Solution: Draw a squared network placing the CP at the centre.

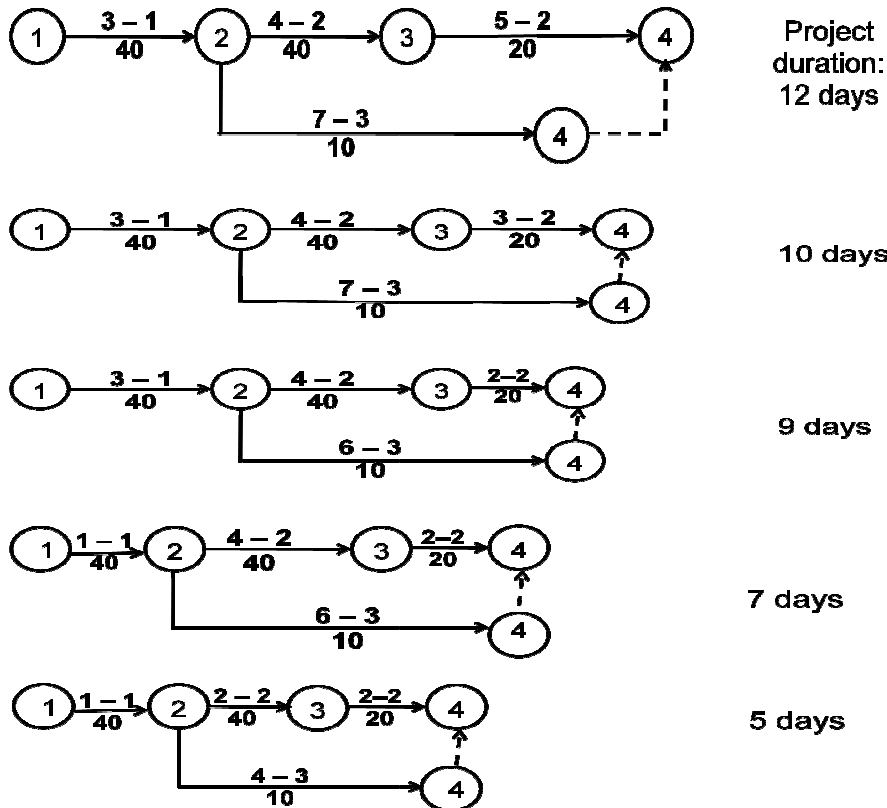

Activity crashed	Days saved	Proj. duration	Cost of crashing	Total Cost of crashing	Over-heads	Total Cost
None	0	12	0	0	540	540
3-4	2	10	$2 \times 20 = 40$	40	450	490
3-4 & 2-4	1	9	$(20+10) \times 1 = 30$	70	405	475
1-2	2	7	$40 \times 2 = 80$	150	315	465
2-3 & 2-4	2	5	$(40+10) \times 2 = 100$	250	225	475

The lowest cost schedule is the plan corresponding to project duration of 7 days.

Problem.8. Table below gives the time and cost data with respect to normal and crash periods of a project. (a) Draw the n/w of the project, (b) What is the normal duration and cost of the project? (c) Determine the project cost if all activities are crashed indiscriminately (d) Determine the optimum project duration, if the indirect cost is Rs. 150/day

Activity	Normal time (days)	Normal cost (Rs.)	Crash time (days)	Crash cost (Rs.)
1-2	3	360	2	400
2-3	6	1400	4	1600
2-4	9	2000	5	2600
2-5	7	1000	5	1500
3-4	8	400	4	600
4-5	5	1600	3	2000
5-6	3	500	2	750

a)

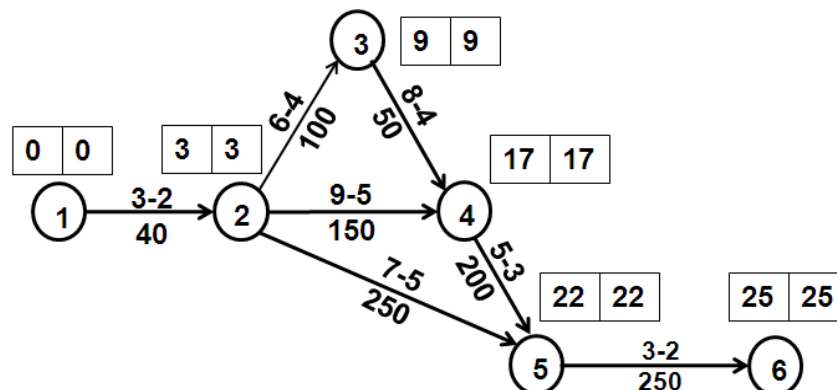

Critical path : 1 – 2 – 3 – 4 – 5 – 6

b) Normal Project Duration : 25 days
 Normal cost of the project is $7,260 + 3,750 = 11,010$

c) Cost of the project if all activities are crashed indiscriminately:

$$= \text{Rs.}9,450 + 2,250 = 11,700$$

d) Now draw a squared network as shown below. Choose the activities on the critical path to crash such that the present critical path continues to remain as (at least one of) the critical path. Also the cost of crashing/day shall be the least among available options at any stage.

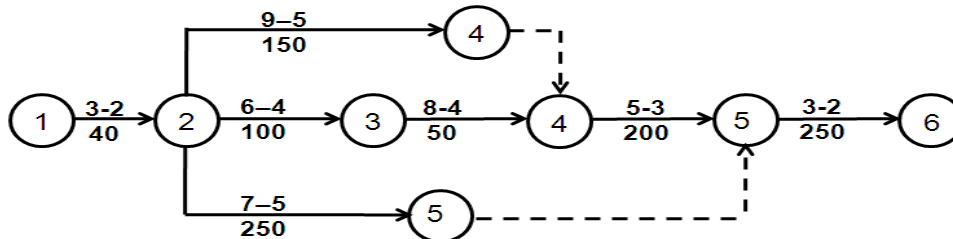

Thus the final crashed network appears as below. The associated cost table is also shown.

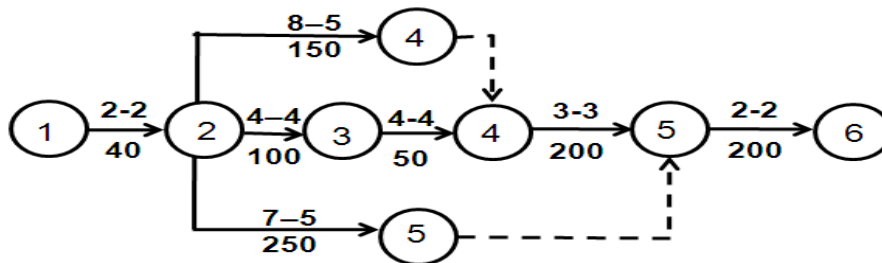

Activity crashed	Days saved (days)	Project durn (days)	Direct cost (Rs.)	Overheads (Rs.)	Total project cost (Rs.)
None	0	25	7260	3750	11,010
1-2	1	24	7300	3600	10,900
3-4	4	20	7500	3000	10,500
2-3	1	19	7600	2850	10,450
4-5	2	17	8000	2,550	10,550
2-3 & 2-4	1	16	8,250	2,400	10,650
5-6	1	15	8,500	2,250	10,750

The table shows that the project duration of 19 days is most economical and optimum.

Program Evaluation and Review Technique (PERT)

Used in such projects where the activities are, to some extent, governed by States-of-nature and the organization does not have full control over the activity duration and hence the time estimates of activities are probabilistic. For example, R&D projects, projects exposed to seasonal variations.

In PERT, we use three time estimates for an activity which reflect the degrees of uncertainty

t_o = Optimistic time: When environment is very favorable

t_m = Most likely time: When environment is just normal

t_p = Pessimistic time: When environment is very unfavorable

There can be a number of time estimates between t_o and t_p

The frequency distribution curve of activity time 't' is assumed to be a β distribution which is unimodal at t_m and has extremes at t_o and t_p . But t_m need not be the mid point between t_o and t_p .

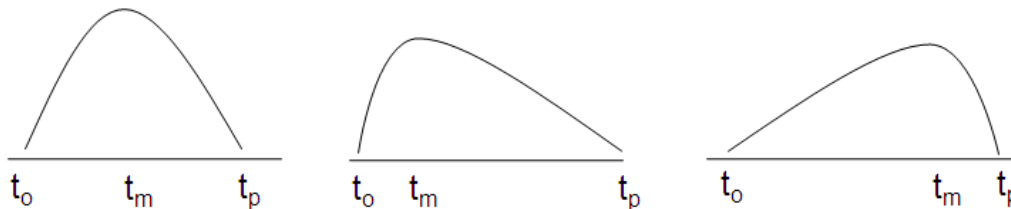

The expected (average) time t_e of an activity is calculated as a weighted average of these three estimates.

$$t_e = (t_o + 4t_m + t_p) / 6 \quad \text{where } t_e \text{ need not be equal to } t_m$$

How reliable t_e is? How confident are we that the activity gets over in time t_e ? This depends upon the spread of the distribution of 't' or variability of 't'. Larger the variation, lesser would the confidence. Example: Distributions with same mean but different spreads

Variance (σ^2) and 'Standard deviation (σ)' are two important measures of variability. In PERT, variance of an activity is calculated as: $\sigma^2 = [(t_p - t_o)/6]^2$

Using t_e s, the earliest and latest occurrences of each event are calculated from which the CP is determined

$$T_e = \Sigma (t_e \text{ of all critical activities})$$

$$\sigma_p^2 = \Sigma (\sigma^2 \text{ of all critical activities})$$

There is a possibility of alternate Critical paths. In such cases we need to consider the critical path with greater variance. As the analysis is based on the probabilistic time estimates even near Critical paths should be carefully examined.

When activity times (' t_j ' for $j= 1, 2, \dots, n$) are independent and identically distributed random variables, then (by Central limit theorem) project duration (T) will follow normal distribution

with expected project duration T_e and project variance σ_p^2 . With T_e and σ_p we can compute the probability of completing the project within a due date using normal PD tables.

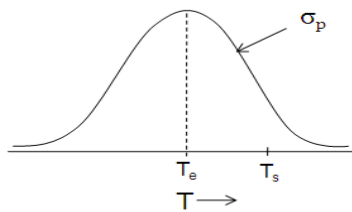

PD of Project duration 'T'

$$Z = (T_s - T_e) / \sigma_p$$

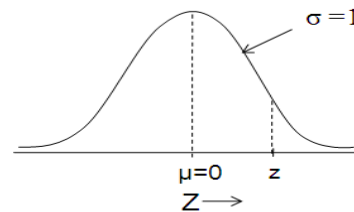

PD of Std normal variable 'Z'

Problem 9. Given the list of activities in a project and their time estimates (in days):

- Draw the project network,
- Determine the critical path(s) and the expected project duration
- What is the probability that project will be completed in 35 days?
- What due date has 90% chance of being met?

Activity	t_o	t_m	t_p
1-2	6	12	30
1-3	3	6	15
1-4	3	9	27
2-6	4	19	28
3-5	3	9	27
3-6	2	5	8
4-5	1	4	7
5-6	6	12	30

a)

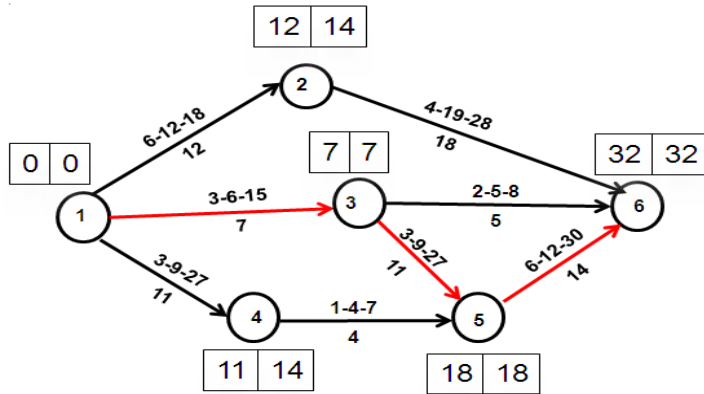

b)

Activity	t_e
1-2	12
1-3	7
1-4	11
2-6	18
3-5	11
3-6	5
4-5	4
5-6	14

Critical path = 1 – 3 – 5 – 6

Expected project duration $T_e = 32$ days

c)

Activity	t_o	t_m	t_p	CA	σ^2
1-2	6	12	18		4
1-3	3	6	15	1-3	4
1-4	3	9	27		16
2-6	4	19	28		16
3-5	3	9	27	3-5	16
3-6	2	5	8		1
4-5	1	4	7		1
5-6	6	12	30	5-6	16

Variance $\sigma_p^2 = 36$ days

Standard deviation $\sigma_p = \sqrt{36} = 6$ days

Expected duration of the project $T_e = 32$ days

Std. deviation of project duration $\sigma_p = 6$ days

Scheduled duration $T_s = 35$ days

We know, $Z = (T_s - T_e)/\sigma_p$
 $= (35-32)/6 = +0.5$

The area under the normal curve (from standard normal PD table) up to $Z = +0.5$
 $= 0.6915$ (i.e. 69.15 % chance)

The probability that project will be completed in 35 days is 0.6915

d)

We know, $Z = (T_s - T_e)/\sigma_p$

For 90% chance (probability = 0.9) area under the std. normal curve, we have $Z = +1.28$

$$+1.28 = (T_s - 32)/6$$

Hence, $T_s = 39.68$ days

Project duration of 39.68 days has 90% chance of being met

Advantages and Limitations of PERT/CPM

Advantages:

- Simple to understand and use
- Show whether the project is on schedule; or behind/ ahead of the schedule
- Identify the activities that need closer attention (critical)
- Determine the flexibility available with activities
- Show potential risk with activities (PERT)
- Provide good documentation of the project activities
- Help to set priorities among activities and resource allocation as per priority

Limitations:

- Demand clearly defined and stable activities
- Precedence relationship should be known in advance
- Overemphasis on Critical path
- Activity time estimates are subjective
- Activity times in PERT may not follow Beta PD in reality
- Cost of crashing an activity may not be linear

Some Computer Software Available for Network Analysis

- Microsoft Project (Microsoft Corp.)
- PowerProject (ASTA Development Inc.)
- Primavera Project Planner (Primavera)

- MacProject (Claris Corp.)

Reference Books:

1. **Taha H A**, Operation Research - An Introduction, Prentice Hall of India, 7th edition, 2003
2. **Ravindran, Phillips and Solberg**, Operations Research : Principles and Practice, John Wiley & Sons, 2nd Edition
3. **D.S.Hira**, Operation Research, S.Chand & Company Ltd., New Delhi, 2004
4. **L.S.Srinath**, PERT and CPM- Principles and Applications, 3rd Edition, Affiliated East-West Press, 2000
5. **Gaither and Frazier**, Operations Management, Thomson, South Western Publishers, 2002